

Solaira[®]

Solaira SCTR 120-240 Variable Controller High Output Variable Heat/Light Control

Suitable for:
ALL QUARTZ BULB AND TUBE HEATERS, CAN BE INSTALLED IN WET ENVIRONMENTS



The Solaira Variable Heat Controller (SCTR 120-240) is a weatherproof, digital, solid-state power control designed to provide a convenient way to variably adjust output on electric appliances (high power infrared heating or lighting). It allows for variable adjusting of the appliance from 10 to 100% of the available power. The control is simple and intuitive with the on/off switch that will turn the appliance on to the last power setting when it was turned off and the "SOFT START" feature will bring the power up slowly to the emitter adding an estimated 25% to the emitter life. The up/down controls are simple to use and the heater or light level is shown on the LED front panel.

WEATHER PROOF

The Solaira Variable Controller is engineered for installation in both indoor or outdoor applications including wet environments. The controller can be used to control heaters on outdoor applications including patios, outdoor structures and pergolas as well as all indoor applications.

POWER SOURCE

MAX LOAD:
1600 Watt, 115-120 VAC, 15.5 AMP Quartz Emitter OR Tube AND HID technology
3200 Watt, 208-240 VAC, 15.5 AMP Quartz Emitter OR Tube AND HID technology
Controller will operate

<u>115 to 120VAC:</u>	One (1) quartz lamps totaling up to 1.6kW One (1) quartz tube totaling up to 1.6kW
<u>208 to 240VAC:</u>	One (1) or two (2) quartz lamps totaling up to 3.2kW Up to two (2) quartz tubes totaling up to 3.2 kW VAC

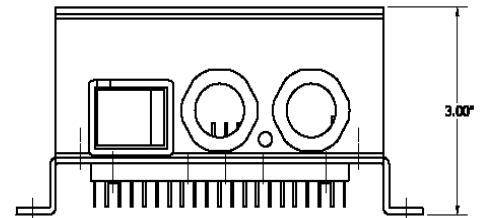
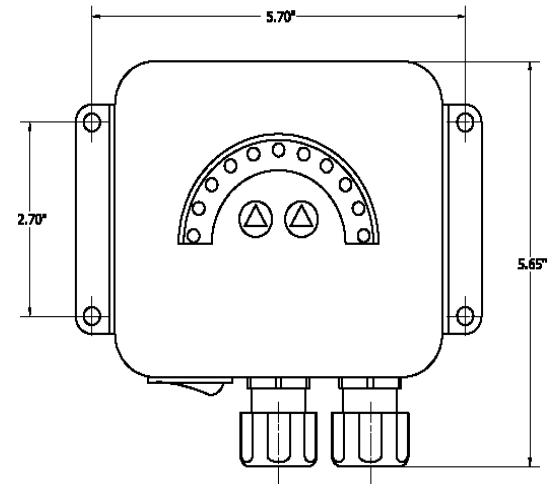

SPECIFICATION

- On/Off switch
- Controllable heat settings from 10 to 100%
- Wall or post mounted
- Accommodates standard 1/2" UL CERTIFIED weather resistant conduit hardware

CONTROLLER MUST BE INSTALLED BY A CERTIFIED ELECTRICIAN TO LOCAL/STATE AND FEDERAL ELECTRICAL CODE

Catalog #:	Description	Wattage	Weight
SCONT 120-240	Solaira Variable control,	max load 1.6kW @115- 120 VAC or 3.2 kW @ 208- 240 VAC	3 LBS

Solaira[®] Specification Submittal

Job Name Catalog Number
Job Number

Inforesight Consumer Products Inc.

Canada: 125 Traders Blvd. E, #4Mississauga, On. L4Z 2H3
US DC: Inforesight Consumer Products Inc. c/o Benlin, 2769 Broadway Blvd, Buffalo, NY 14227
Phone: 905-568-7655 Fax: 905-568-7521

Solaira[®]

